

MASTER MODERN 3D MEASUREMENT PLANNING

Digitalizing dimensional requirements
for smarter manufacturing

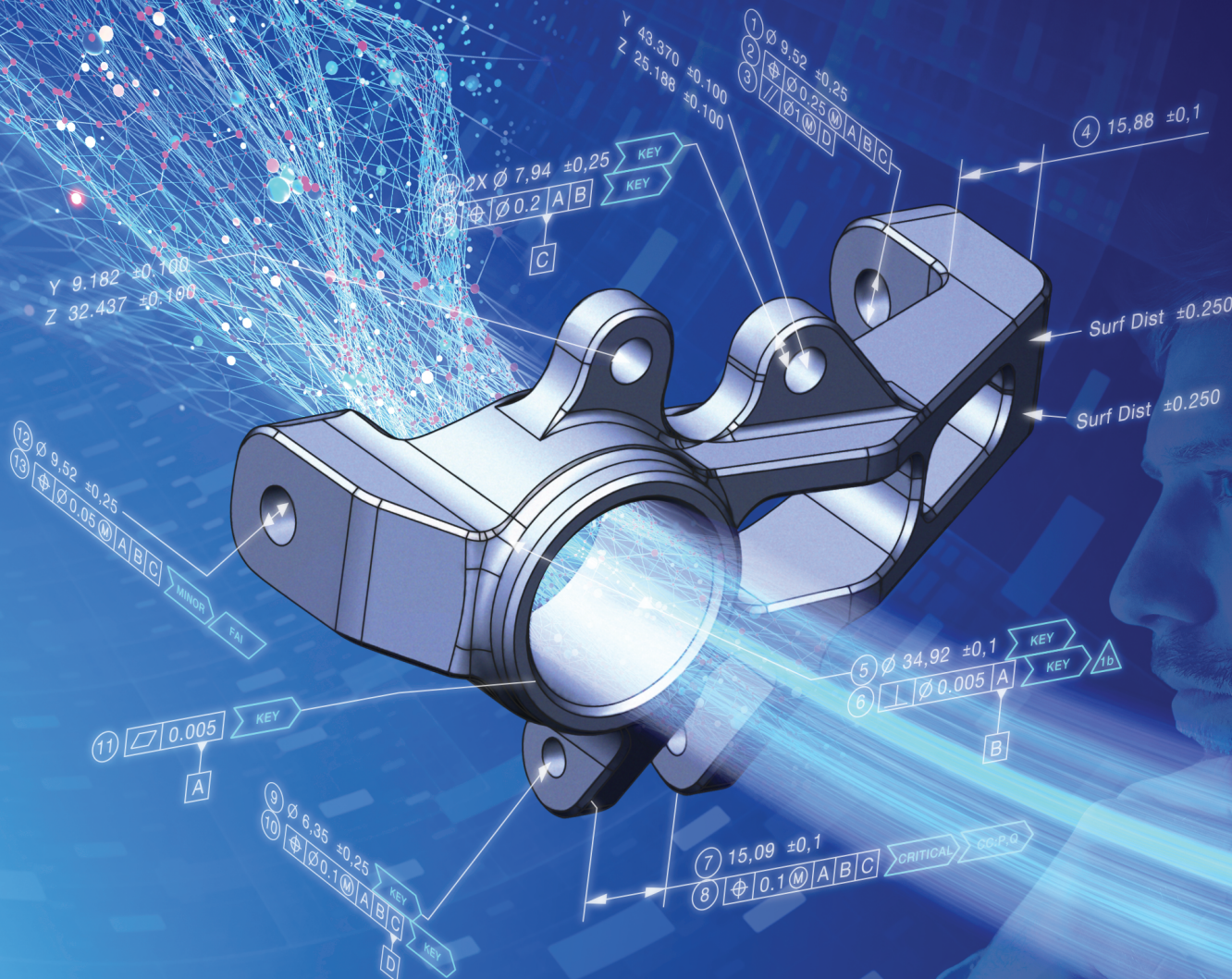

Introduction

There is more to creating a new part than solely defining its three-dimensional shape. As reality never exactly matches intent, the **design team** also needs to provide dimensional specifications along with their 3D models to downstream teams. The **manufacturing team** needs exact 3D geometries and characteristics to determine the fabrication processes and define their specifications. And the **quality control team** needs references to measure fabricated pieces and determine if they meet design and manufacturing requirements. Precise feedback from quality on failing parts helps manufacturing to make necessary adjustments. Clearly, the **efficient flow of information** to and from quality control is a key factor in maintaining product quality.

Each company has its own recipe for sharing dimensional requirements by encoding them within CAD models, product manufacturing information (PMI) and comma-separated values (CSV) files, 2D drawings, bills of characteristics documents, and more. On reception, the quality control team spends precious time finding the information they need, translating and adapting design intent to their processes and software platforms while trying to **avoid transcription and interpretation errors**. When a design change is made, extraordinary efforts must be deployed to **correctly update quality control processes and documentation**, including CNC CMM programs and inspection sequences. And without an efficient and dependable information-sharing system, errors and costs are guaranteed to increase.

This white paper looks at the two main approaches used by organizations today to share design and manufacturing dimensional requirements with quality control teams. It also highlights the approaches' strong points, issues, and limitations. It explains how the digitalization of this process addresses existing shortcomings to significantly improve efficiencies, transforming this essential function from a burden into an asset.

3D Measurement Plan Essentials

First, let's review the big picture. To **convey the dimensional requirements** from the design and manufacturing teams to the 3D measurement team within quality control, manufacturing organizations use a communication tool called the dimensional inspection plan, i.e., the 3D measurement plan. This plan specifies **what needs to be measured and how it should be measured**. It typically contains:

- Design requirements, such as geometric dimensioning and tolerancing (GD&T), standard dimensions, and custom dimensions;
- Manufacturing requirements, including feature locations, and surface and edge deviations;
- References to 3D geometries or explicit measurement object definitions;
- Additional attributes to support internal processes, such as dimension numbering, criticality classification, and traceability information.

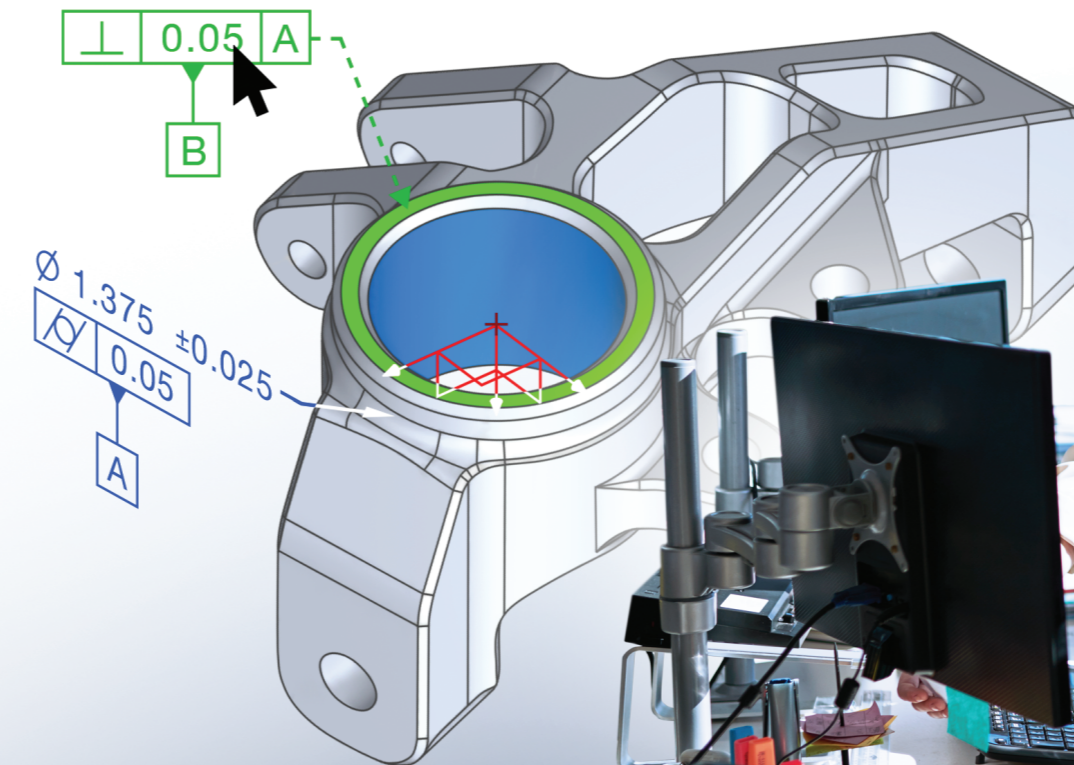

Ballooning is often used to attribute a unique numerical identifier to each key piece of information to ensure traceability and to facilitate communication. What changes from one organization to another is **how the 3D measurement plan is assembled**, plus its level of **user-friendliness for the downstream teams**.

Additionally, the time and effort required for the manufacturing and quality control teams to **integrate, communicate, and apply a new design change** can be considerably different from one business to another.

List of Characteristics

Work View Filter characteristics

Char No.	Char Name	Control	Model Views	Criticality Level	Criticality Category	Verification Plan Requirement	Flag Note	Engineering and Inspection Flag Notes
1	Linear Dimension (20)	15.09 ± 0.10	TOP VIEW, ISO			D:SCAN:100%		
2	Feature Control Frame (89)	$\phi 0.100 \text{ (M) A B C}$	TOP VIEW, ISO	CRITICAL	P,Q	D:SCAN:100%		
3	Linear Dimension (21)	15.88 ± 0.10	TOP VIEW, ISO			D:SCAN:100%		
4	Feature Control Frame (102)	0.005	Left, ISO	KEY			1a	Avoid clamping on datum geometry
	Datum Feature Symbol A (103)	A	Left, ISO					
5	Radial Dimension (99)	$\phi 34.92 \pm 0.10$	Left, ISO	KEY		D:SCAN:100%		
6	Feature Control Frame (100)	0.005 A	Left, ISO	KEY		D:SCAN:100%	1a	Avoid clamping on datum geometry
	Datum Feature Symbol B (101)	B	Left, ISO					
7	Radial Dimension (94)	$2X \phi 7.94 \pm 0.25$	Left, ISO	KEY		D:SCAN:100%	1a	Avoid clamping on datum geometry
8	Feature Control Frame (95)	$\phi 0.200 \text{ (M) A B}$	Left, ISO	KEY		D:SCAN:100%		
	Datum Feature Symbol C (96)	C	Left, ISO					

4

3D Measurement Planning with 2D Drawings

Complete description of design and manufacturing requirements at a time when digital processes were not yet available

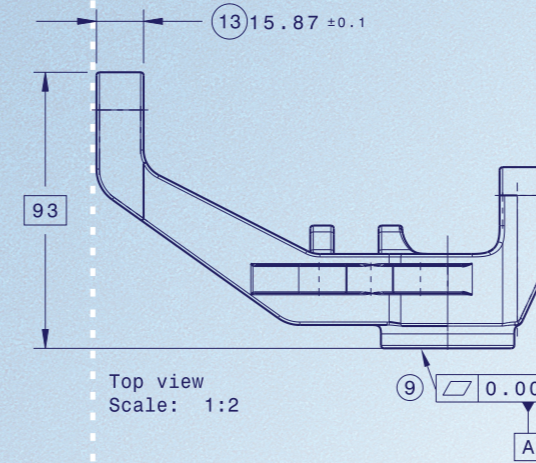

Many manufacturing organizations use 2D drawings to communicate **three-dimensional requirements** to their 3D measurement inspection teams. 2D drawings are also frequently used to produce legal documentation. They consist of a number of 2D views created from a part's 3D model and include the part's dimensional requirements on each view.

With these 2D drawings, **design requirements**, such as GD&T and dimensions, are represented using graphical elements such as text, symbols, distances, and angles. These graphical elements are attached to locations on the part's model to indicate where measurements should be made. Additional attributes are often included as notes.

2D drawings also contain **manufacturing requirements**. For example, X, Y, Z symbols provide coordinates for individual feature requirements. Tables containing lists of 3D coordinates can also be used to indicate where point deviations are needed to make corrections.

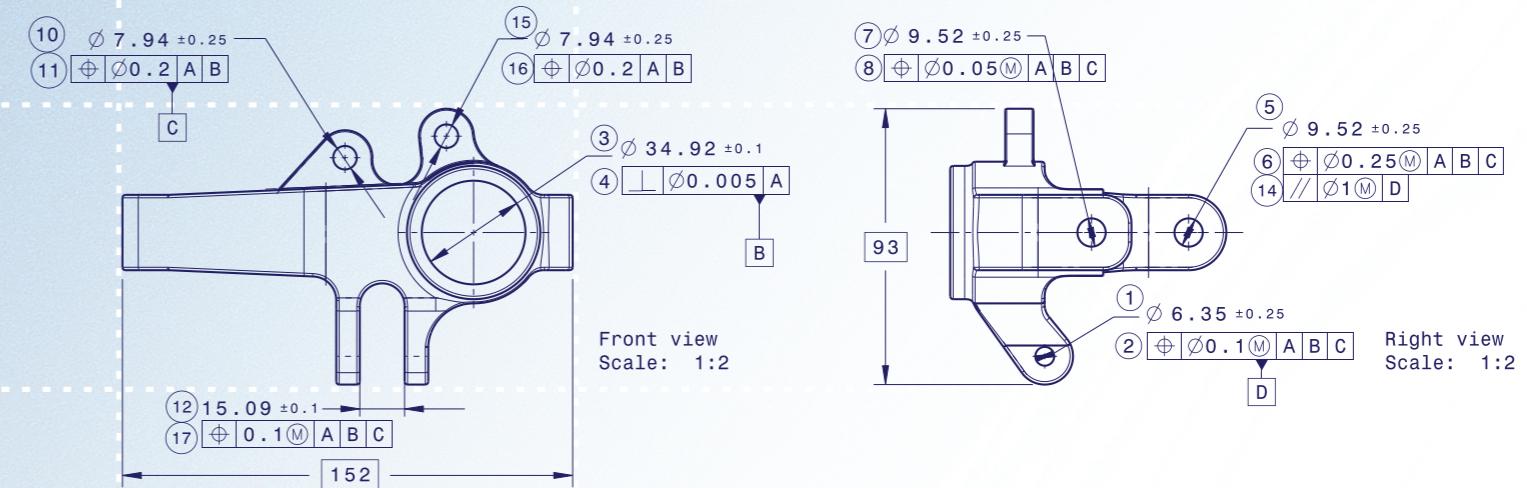

5

Once 3D measurement teams receive 2D drawings, they open their 3D inspection software, **read and interpret each 2D drawing**, and then create the objects and dimensions that need to be measured. In the early days of 2D drawings, they were printed on large sheets of paper, in many cases at a 1:1 scale. Measurement specialists would use inspection stamps to create balloons and number each measured dimension manually.

There are two major drawbacks when using 2D drawings for 3D measurement planning:

- 3D measurement specialists who need to interpret the 2D drawings have to **manually determine and create** the geometry and dimensions to be measured within 3D inspection software, which is a time-consuming process prone to typing mistakes and interpretation errors.
- In addition, integrating a necessary design change is painful. Often, **identifying the differences between the new and old revisions** of 2D drawings is difficult for 3D measurement teams. In such cases, they generally prefer to recreate their 3D inspection project from scratch.

The 2D drawing process is still in use today, as it is legally required in many industries to produce them. Of course, the technology has evolved. 2D drawings can now be created automatically from 3D CAD models. They can also be saved to PDF files instead of printed. Moreover, several software solutions offer a virtual ballooning process to number dimensions digitally and create inspection reports. These technological evolutions have streamlined the 2D drawing process, but nevertheless, preparing 3D inspection projects from 2D drawings still involves interpretation as well as manual operations, and offers no relief for CAD revision management. Furthermore, **2D drawings lack the digital traceability and interoperability** required to convey technical information to 3D inspection software and implement robust digital 3D measurement planning processes.



3D Measurement Planning with Model-Based Definition

A step-forward solution toward an entirely digital workflow

Model-Based Definition (MBD) is an emerging approach to creating 3D CAD models so that they effectively contain all the technical data needed to define a product's form, fit, and function throughout its lifecycle. The core of MBD is a **digitally annotated 3D CAD model, natively within CAD software**, that contains 3D geometry, product manufacturing information, metadata, and other design or manufacturing information. With MBD, the 3D CAD model becomes the **single source of authority** for all stakeholders within the organization and thus eliminates the need for 2D drawings as the source of authority for conveying the technical data.

The significant benefit delivered by MBD technology is that once product **specifications are tied to CAD geometry**, they can be **automatically updated** when the CAD model is modified. This means all contents of a 3D measurement plan would always be in sync with CAD data within CAD software and the consumption of the 3D measurement plans by 3D inspection software could be automated, saving time and eliminating human errors. Although very promising, there are a few stumbling blocks to this approach.

Product manufacturing information (**PMI**) is a **native CAD software technology** used within the MBD approach to **convey design requirements** to the manufacturing team for manufacturing product components and assemblies. With PMI, engineering can create design requirements such as 3D dimensions, GD&T, surface finish, bills of material and other annotations, and associate these requirements to the appropriate 3D CAD geometry.

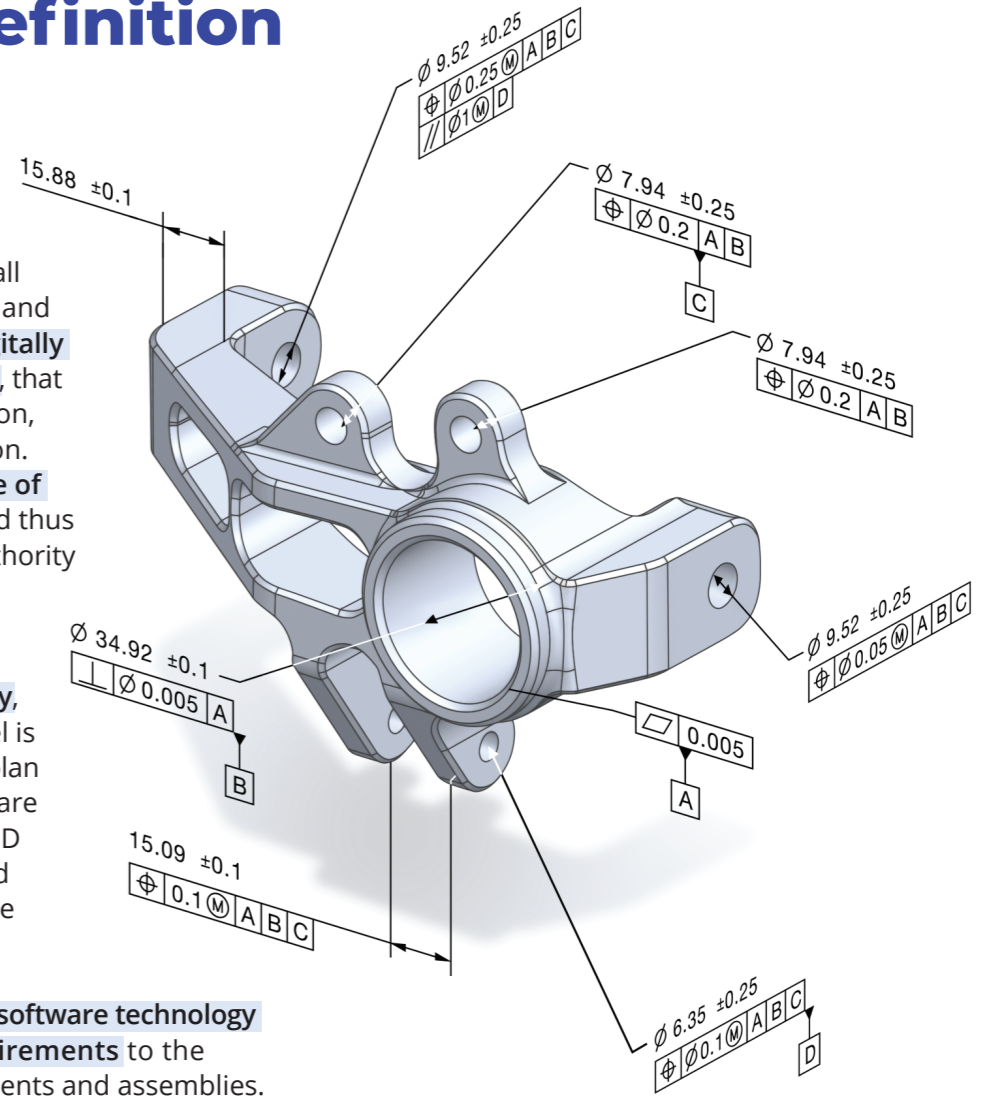

Thanks to the direct association between dimensional requirements and 3D model geometry that digitally emulates certain capabilities of 2D drawings, PMI technology allows 3D inspection software to **import CAD-based part models and automate the creation of objects and dimensions** to be measured, reducing the number of manual operations required and eliminating the need to interpret 2D drawings.



However, with PMI technology not designed to provide all the **requirements** for 3D measurement applications, three major limitations can be identified when used for measurement planning:

→ Many types of requirements routinely needed for dimensional analysis for manufacturing cannot be defined using the native PMI dimensioning toolset and have to be created within 3D inspection software. Examples include:

- surface and edge deviations at specific locations;
- specialized dimensions, for example on airfoils;
- dimensions on construction geometry, i.e., with geometrical measurement dependencies;
- dimensions tied to specific coordinate systems.

8

→ While PMI helps digitalize the creation of initial 3D measurement plans, change management remains inefficient. PMI updates automatically within CAD software when CAD model geometry changes. However, 3D inspection software cannot automatically figure out what has changed when importing a new CAD model revision. This leads many customers to rebuild their 3D inspection project from scratch.

→ PMI representing in-process requirements, rules, and other extra data cannot easily be interpreted by 3D inspection software and requires manual interventions to be translated as intended.

Due to these limitations, 3D inspection software can only obtain **partial 3D measurement plans from current MBD CAD models**, requiring further manual processing from the quality control team, a tedious task that also plagues 2D drawing-based measurement planning processes.

By automating the consumption of design requirements, CAD software's **PMI technology improves the speed of creating the first revision** of a 3D inspection project. But key technological foundations are still missing to offer a digital 3D measurement planning process capable of replacing 2D drawing-based options.

With MBD holding great promise for providing rich 3D models to the whole organization, addressing the increasing complexity of systems with semantic interoperability, can its current limitations be overcome?



Model-Based Definition Solution Tailored to 3D Measurement Planning

The modern solution to define all design, manufacturing, and in-process 3D inspection requirements natively within CAD software, with end-to-end digital traceability

InnovMetric has designed the **PolyWorks® MBD solution** to provide the technologies required to digitalize the entire 3D measurement planning process: from creating CAD-based 3D measurement plans that **integrate all dimensional requirements**, to **automating the consumption of MBD CAD models** with their associated 3D measurement plans by 3D inspection software.

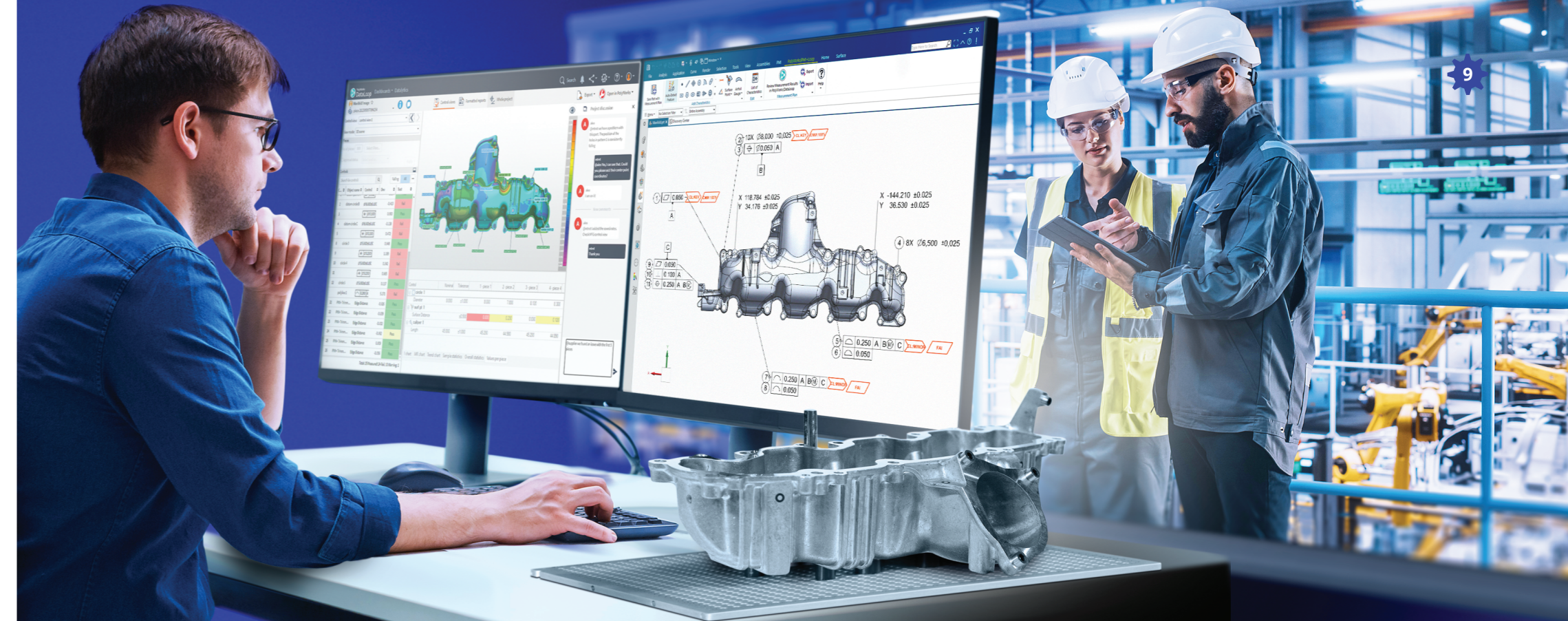

9



To address the shortcomings of the native PMI technology and the digital traceability limitations of the MBD approach, InnovMetric offers **PolyWorks add-ins for CAD platforms** to define **complete 3D measurement plans** associative with **CAD geometry** and **enrich CAD models with digital traceability**, allowing users to:



- Set up specialized dimensional requirements and tie them to different coordinate systems;
- Define PMI on construction-based geometry;
- Review, order, and supplement bills of characteristics with process and inspection requirements;
- Update 3D measurement plans automatically within 3D inspection software.

There are several remarkable aspects to adopting PolyWorks' MBD-based **digital 3D measurement planning workflow** for your engineering, manufacturing, and quality control teams:

- Because **all requirements defined by the PolyWorks MBD solution are created using native CAD PMI technology**, 3D measurement plans can be reviewed within any CAD/PLM viewer, shared using neutral file formats, and digitally consumed by CAD/CAM-based downstream applications.
- The digital traceability is built-in within dimensional requirements and the CAD model, thus ensuring **updatability of 3D measurement plans within 3D inspection software**, and allowing the tracking of the 3D inspection projects built from a given CAD model and 3D measurement plan.
- In a single click, CAD and PLM users can now **access the 3D measurement data and digital twin instance**, along with the dimensional inspection results of any part; this feedback loop generates a new and productive starting point for subsequent design efforts.



Take Part in the Beginning of a New Era

Mastering modern 3D measurement planning and obtaining a comprehensive digital 3D measurement plan are pivotal assets in improving productivity and **digital interoperability between your engineering, manufacturing, and quality control teams**.

At InnovMetric, we believe that deploying a digital 3D measurement planning workflow should be part of any manufacturing organization's digital transformation roadmap. Move from a half-automated, half-manual approach to a fully integrated digital 3D measurement plan that **eliminates wasted time and data transfer inaccuracies**. With PolyWorks MBD-based digital 3D measurement planning, a new era of **digital interoperability between CAD software and 3D inspection software** has begun. Silos are eradicated at their very source, laying the foundation for enhanced productivity and accuracy.

Ensuring 3D measurement planning efficiency and results is no longer an afterthought nor is it a burden. Complete digital 3D measurement planning is now available for leading CAD platforms. Take advantage of this forward shift in thinking and the **real productivity benefits** it provides your entire organization by **contacting InnovMetric today**.



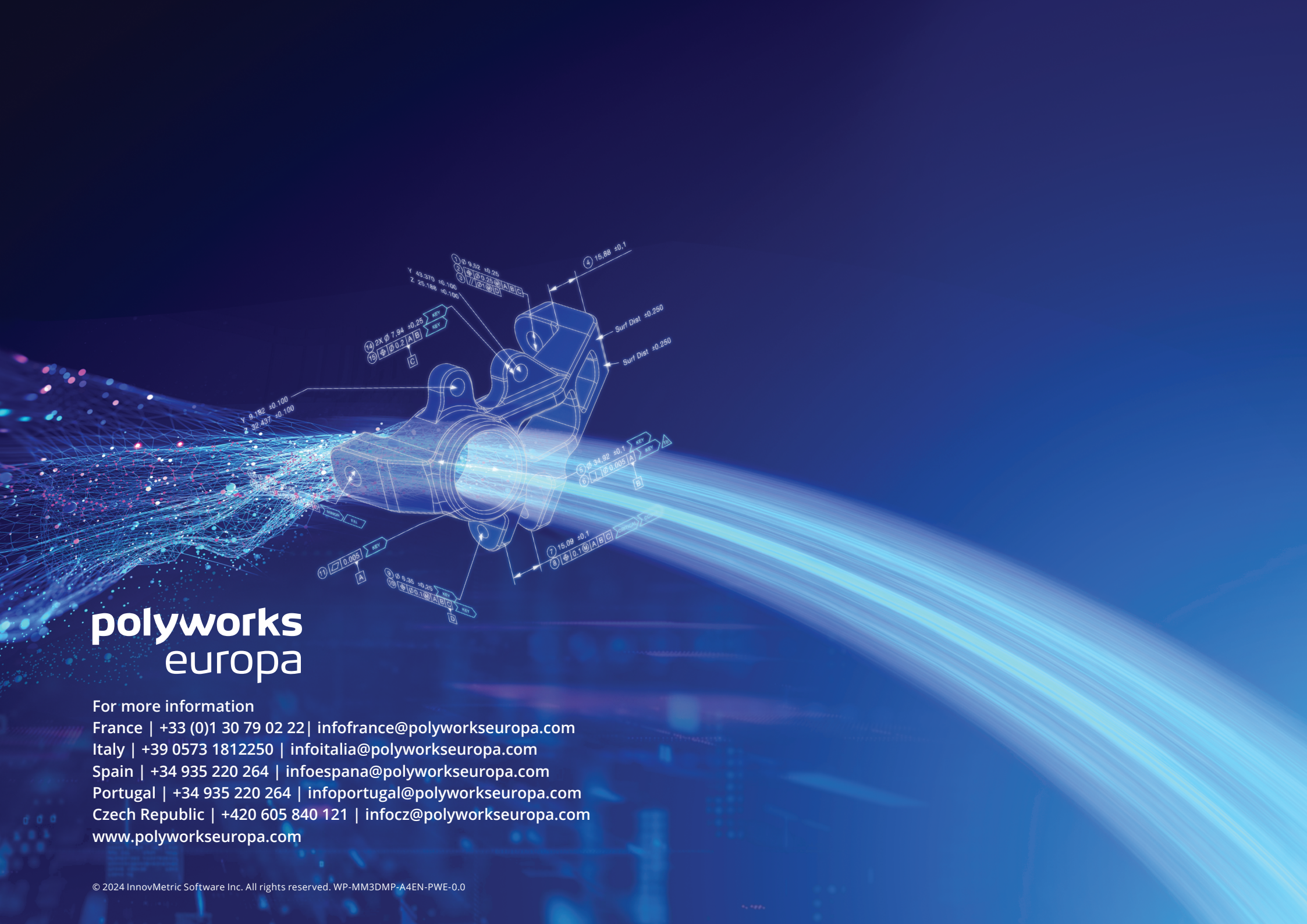

polyworks europa

For more information
France | +33 (0)1 30 79 02 22 | infofrance@polyworkseuropa.com
Italy | +39 0573 1812250 | infoitalia@polyworkseuropa.com
Spain | +34 935 220 264 | infoespana@polyworkseuropa.com
Portugal | +34 935 220 264 | infoportugal@polyworkseuropa.com
Czech Republic | +420 605 840 121 | infocz@polyworkseuropa.com
www.polyworkseuropa.com